

**a) Aufbau eines Neurons**

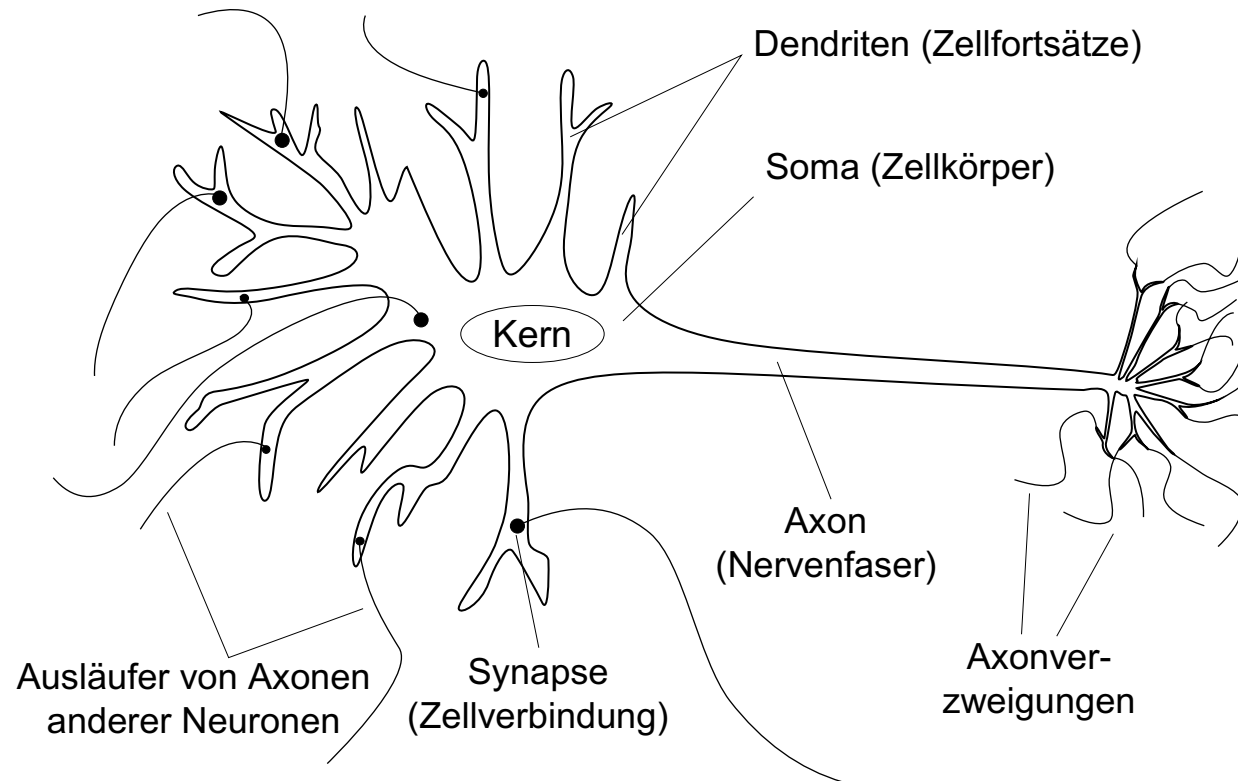

## b) Informationsfluß in einem Neuron

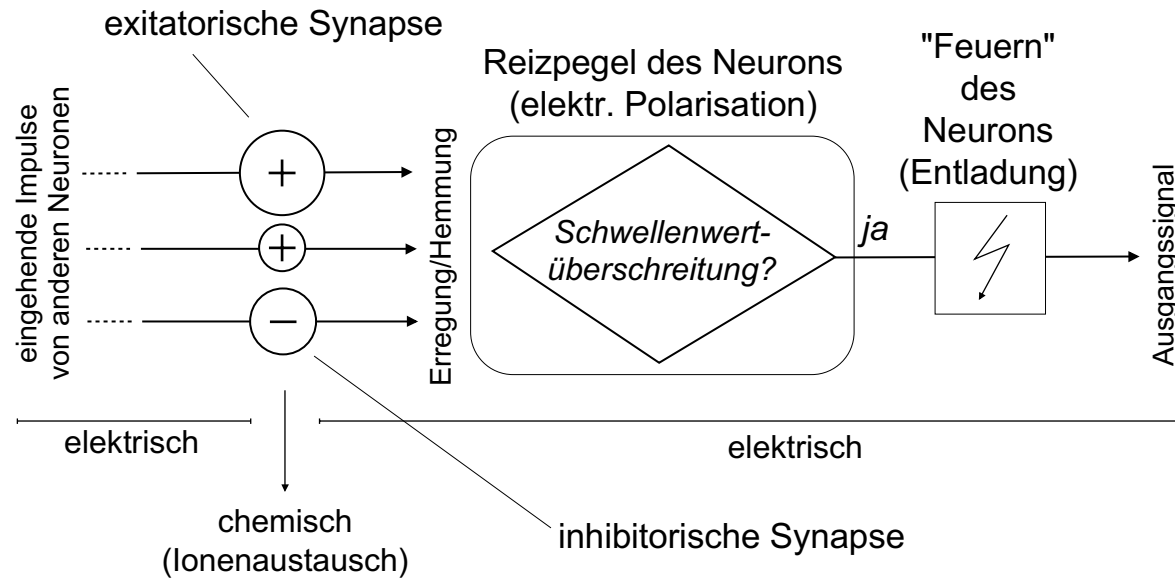

### Daten zum menschlichen Gehirn:

- Zellkörperdurchmesser: 5 - 100  $\mu$  ( $1\mu = 1/1000000$  m)
- ca. 1.000 - 10.000 Querverbindungen/Neuron
- durchschnittl. Gewicht: 1375 g (Männer) bzw. 1245 g (Frauen)

- Anzahl der Neuronen: ca. 10-100 Mrd.
- Länge der zusammengefaßten Nervenverbindungen: ca. 500 Mio. m

Aufbau und Funktionalität eines künstlichen Neurons  $N_j$  in Analogie zum biologischen Vorbild

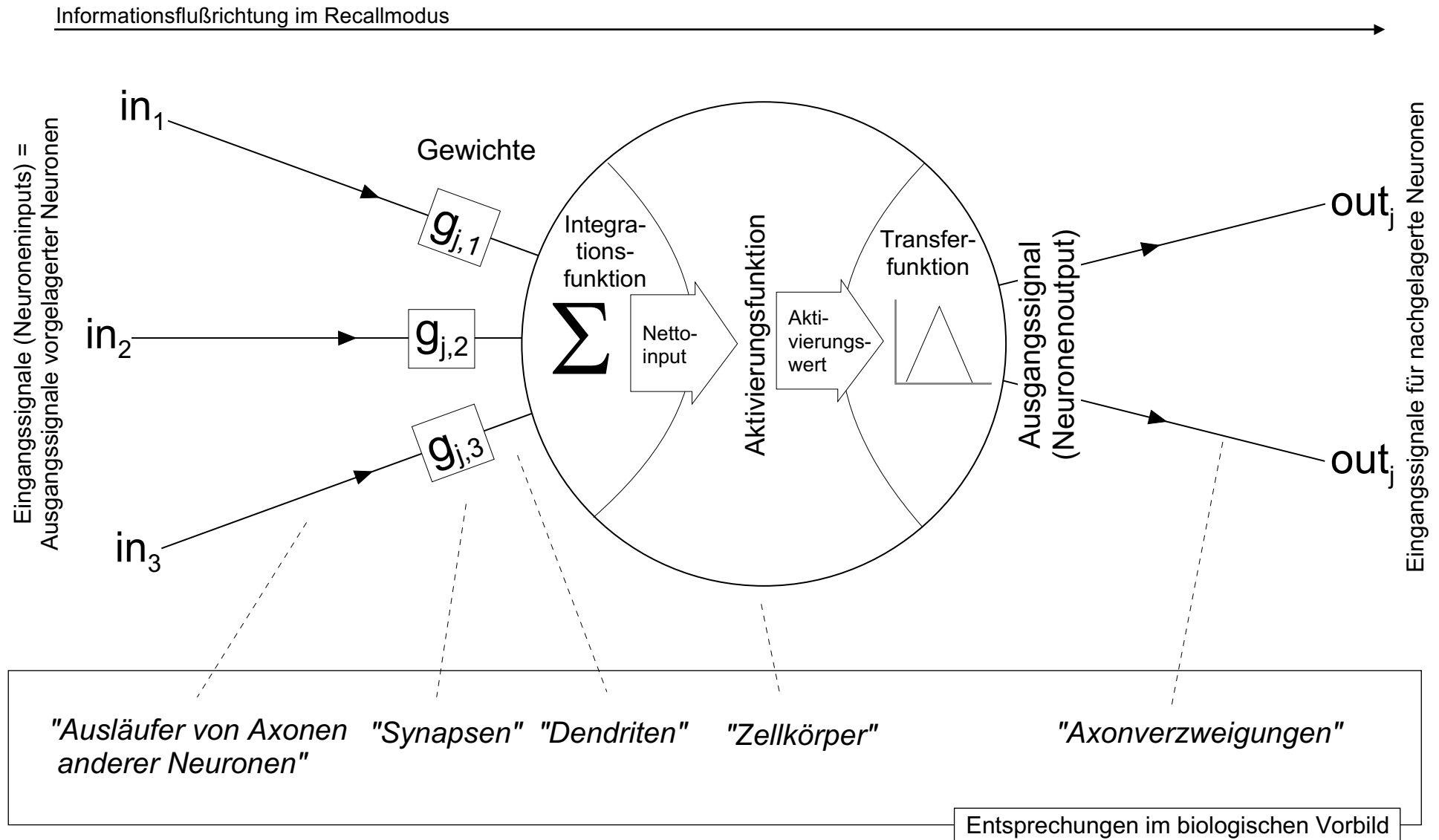

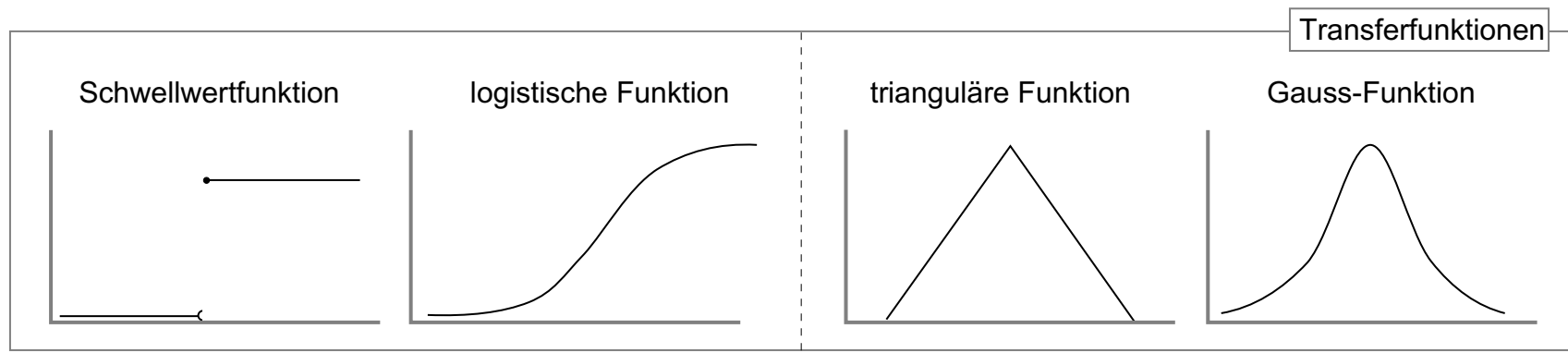
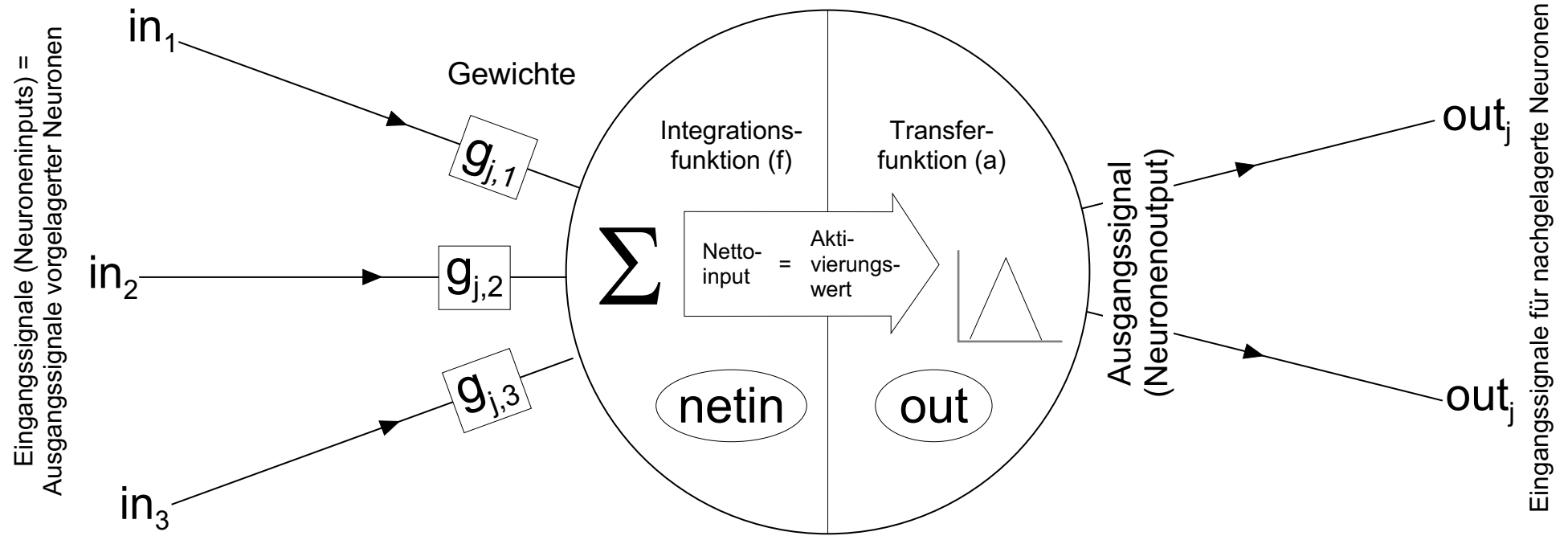



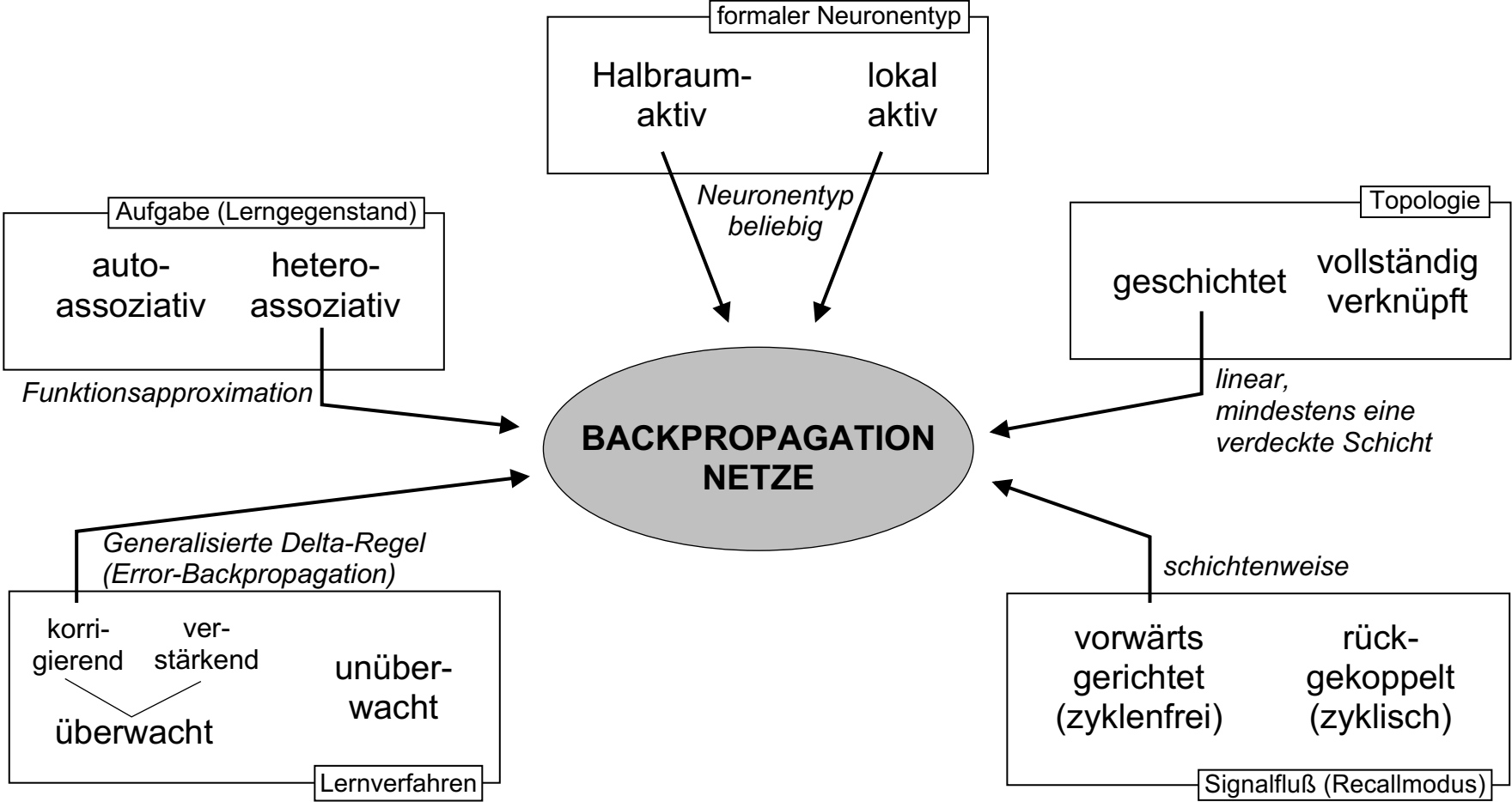

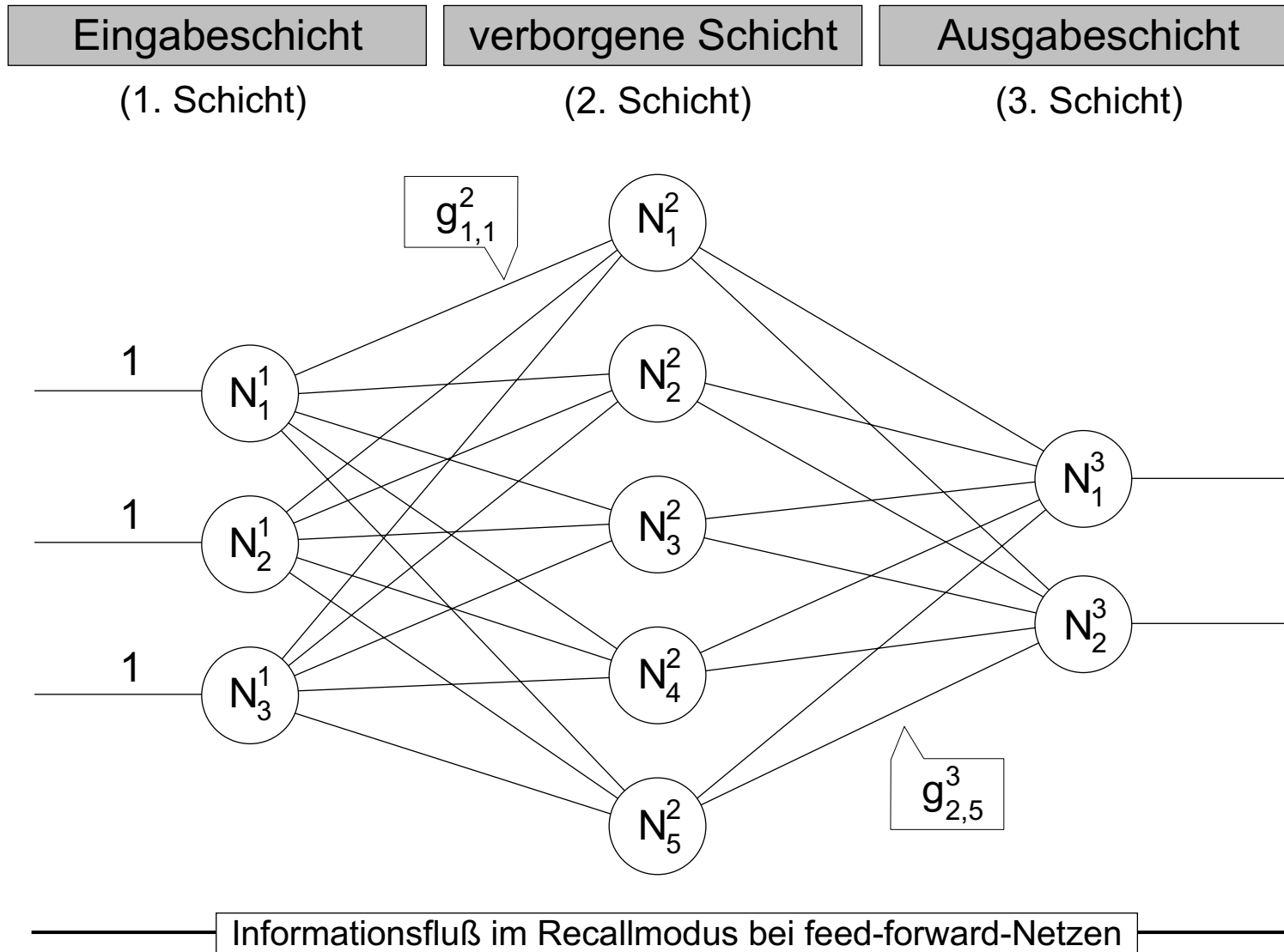

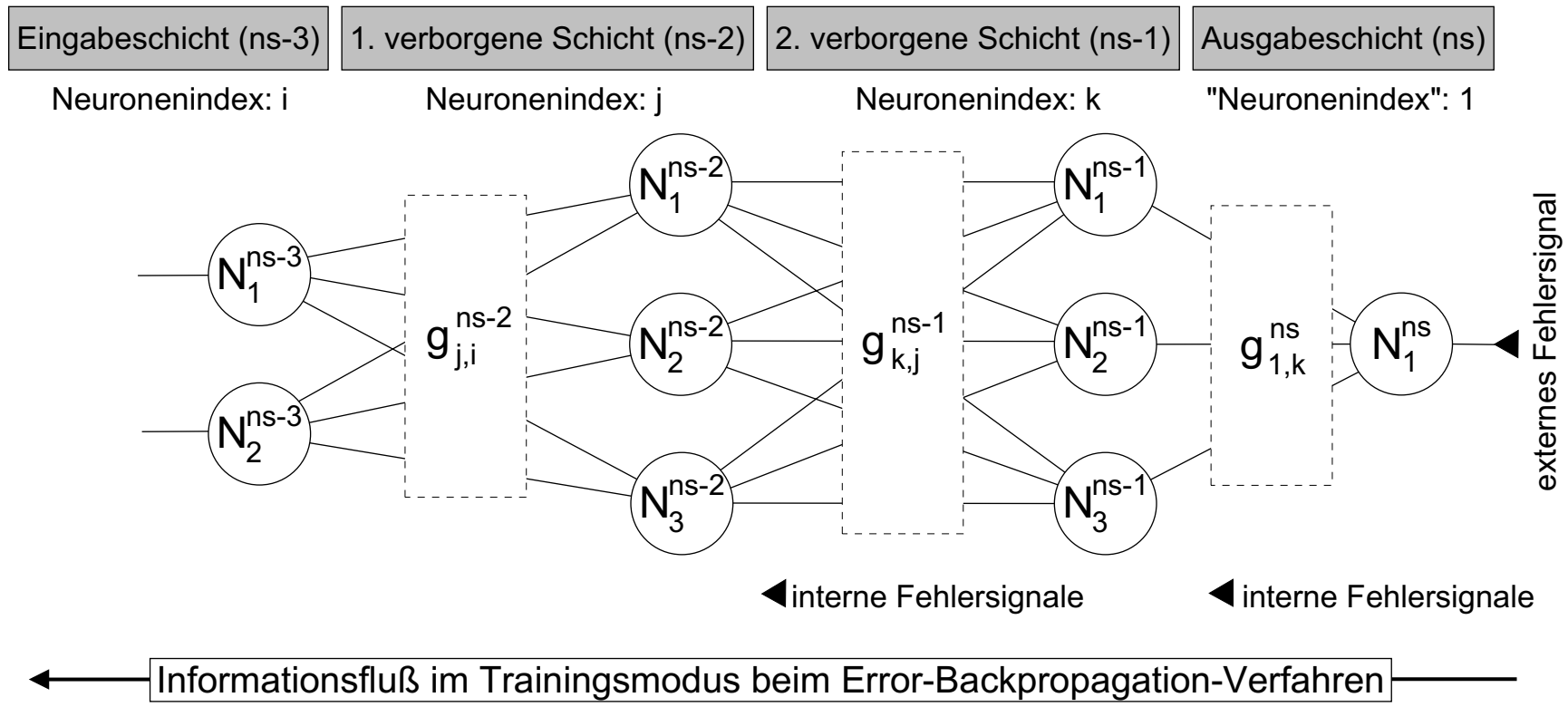

Informationsflußrichtung im backward-pass (Lernmodus)

"synaptische Plastizität"  $\frac{\partial \text{Netzfehler}}{\partial \text{Gewichte}_v} = \frac{\partial \text{Netto-Input}_v}{\partial \text{Gewichte}_v} \text{Fehlersignal}_v \longrightarrow \text{Gradientenabstieg}$

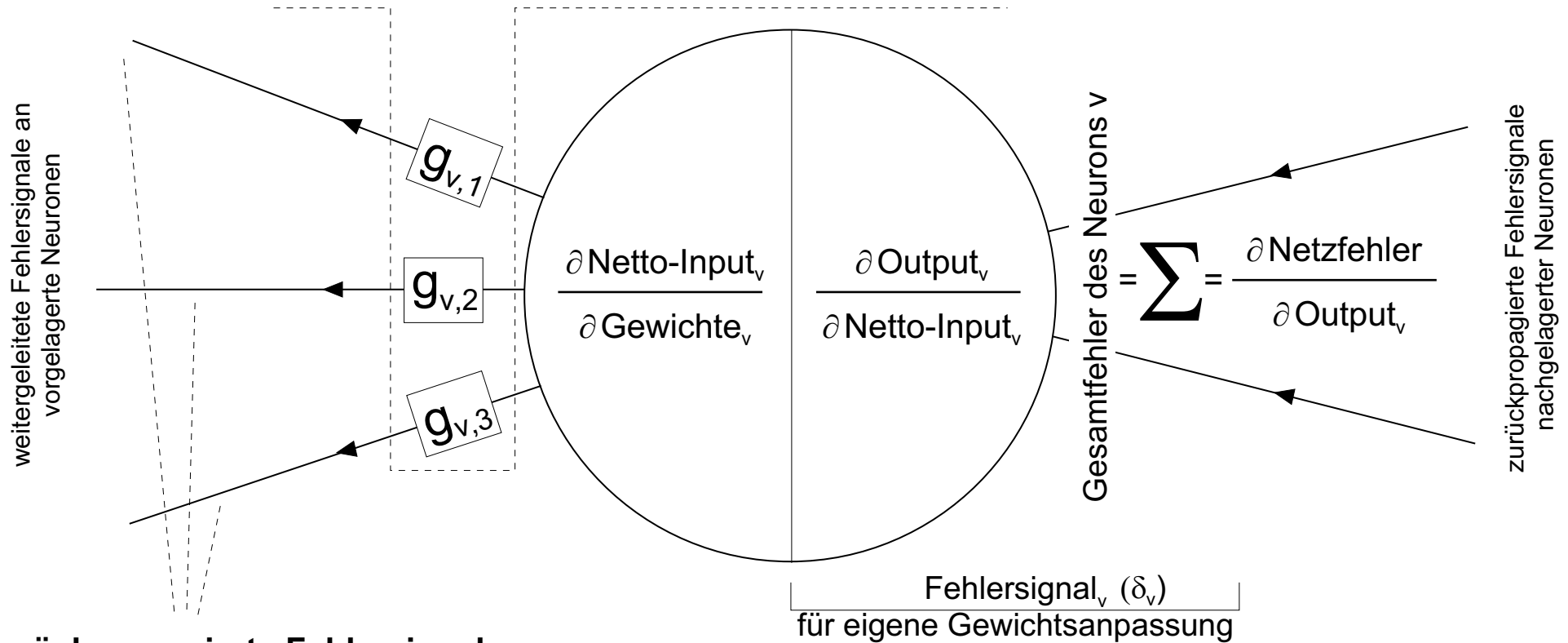

**zurückpropagierte Fehlersignale:**

$$\frac{\partial \text{Netto-Input}_v}{\partial \text{Output}^w \text{ vorgelagert } v} \text{Fehlersignal}_v = \frac{\partial \text{Netto-Input}_v}{\partial \text{Output}^w \text{ vorgelagert } v} \frac{\partial \text{Output}_v}{\partial \text{Netto-Input}_v} \frac{\partial \text{Netzfehler}}{\partial \text{Output}_v}$$

a) Klassischer und Fuzzy-Mengenbegriff im Vergleich

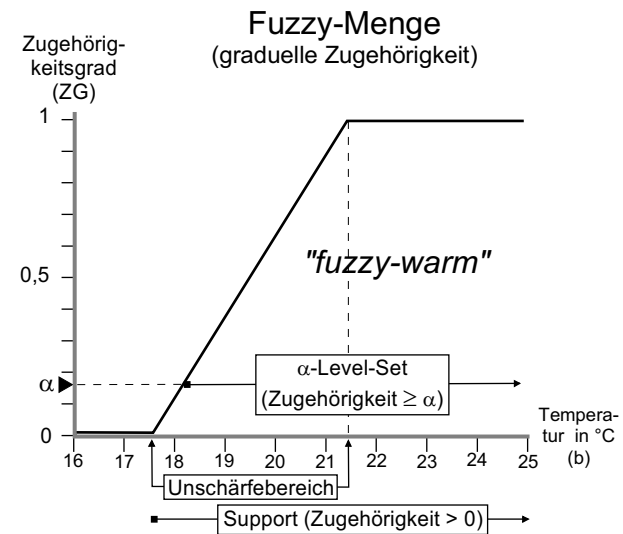
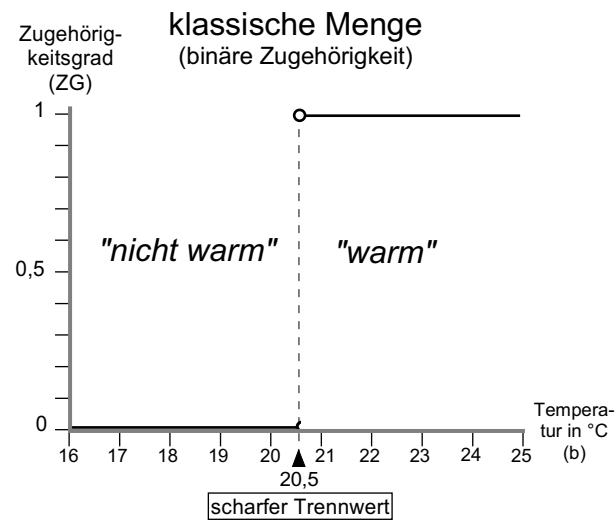

**b) Fuzzifizierung: Partitionierung einer Basisgröße mit Fuzzy-Mengen**

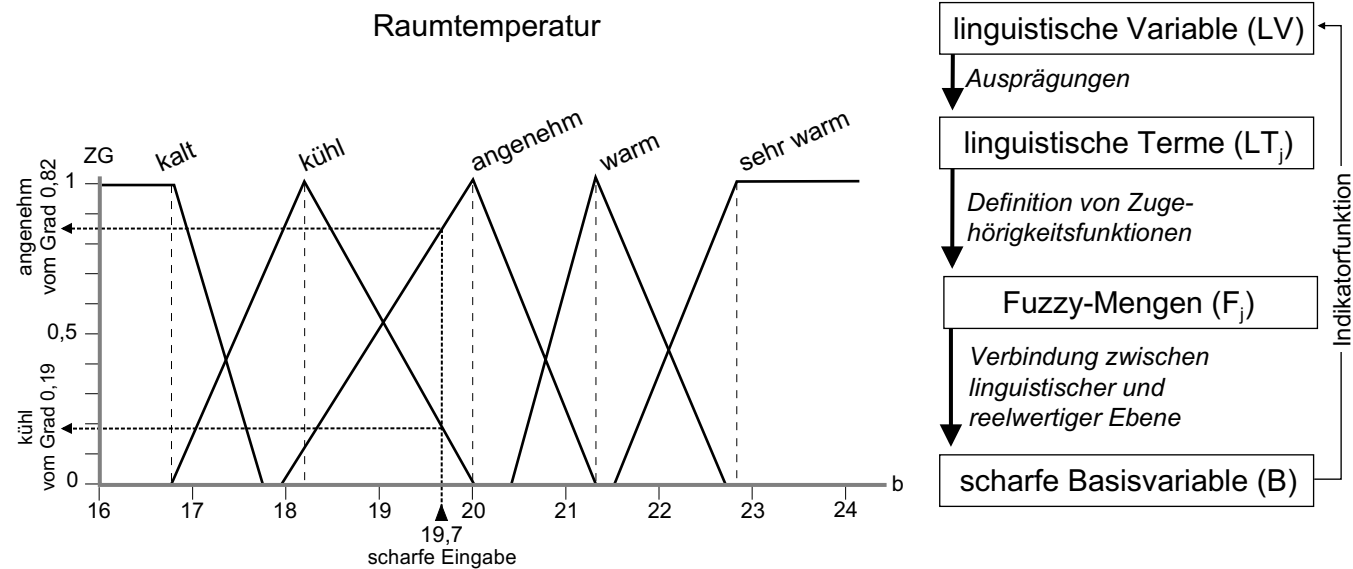

a) Stilisierte Form einer Fuzzy-Regel

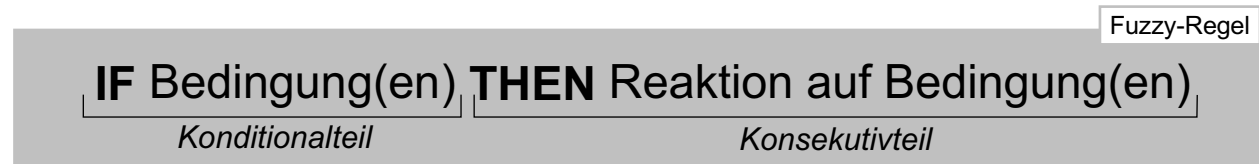

b) Inferenzprinzip

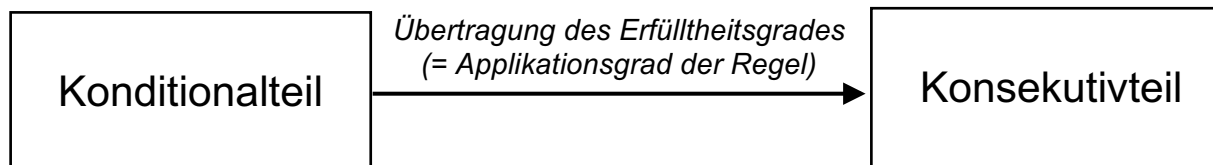

c) Beispiel (Regelauswertung mittels Skalierungsverfahren)

**IF** (Arbeitslosigkeit = "hoch") **THEN** (Inflation = "niedrig")

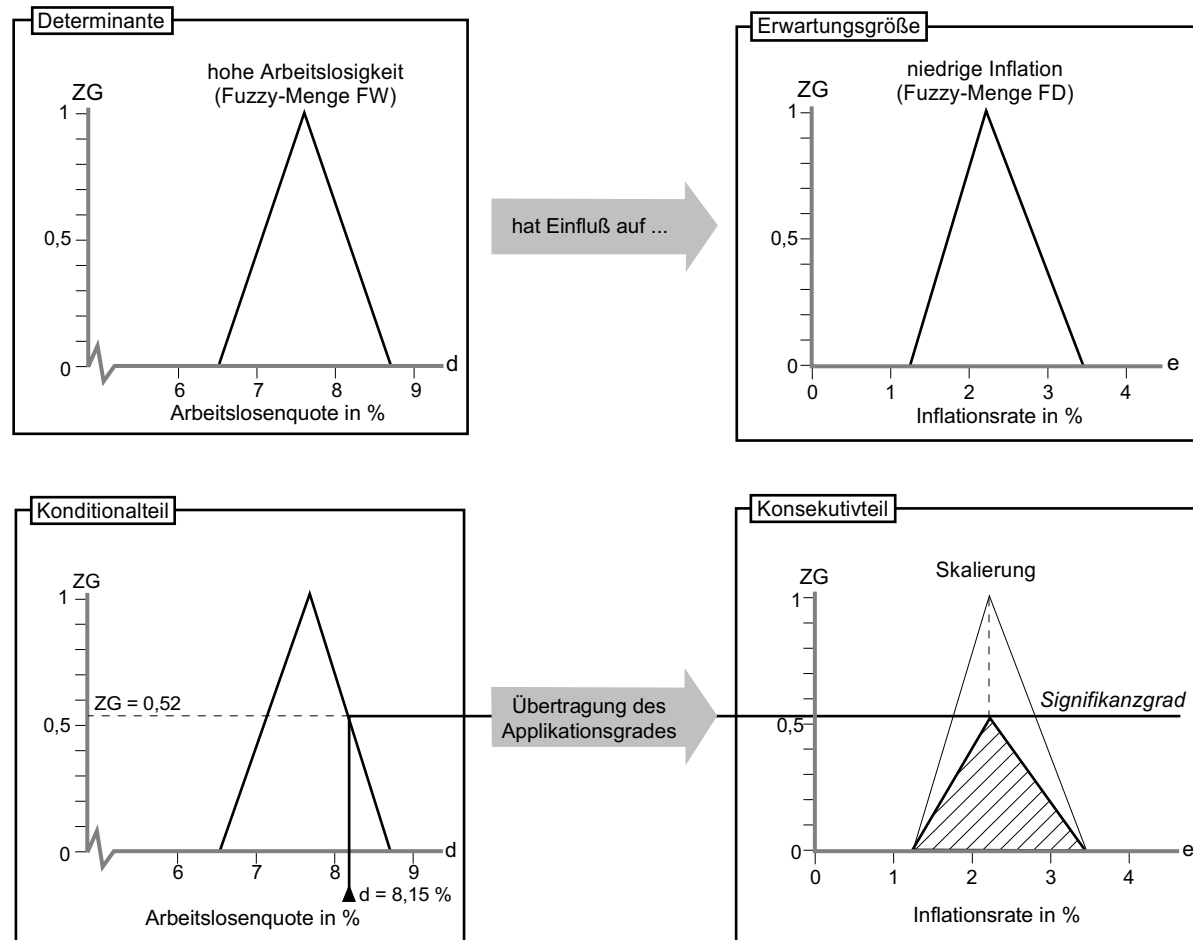

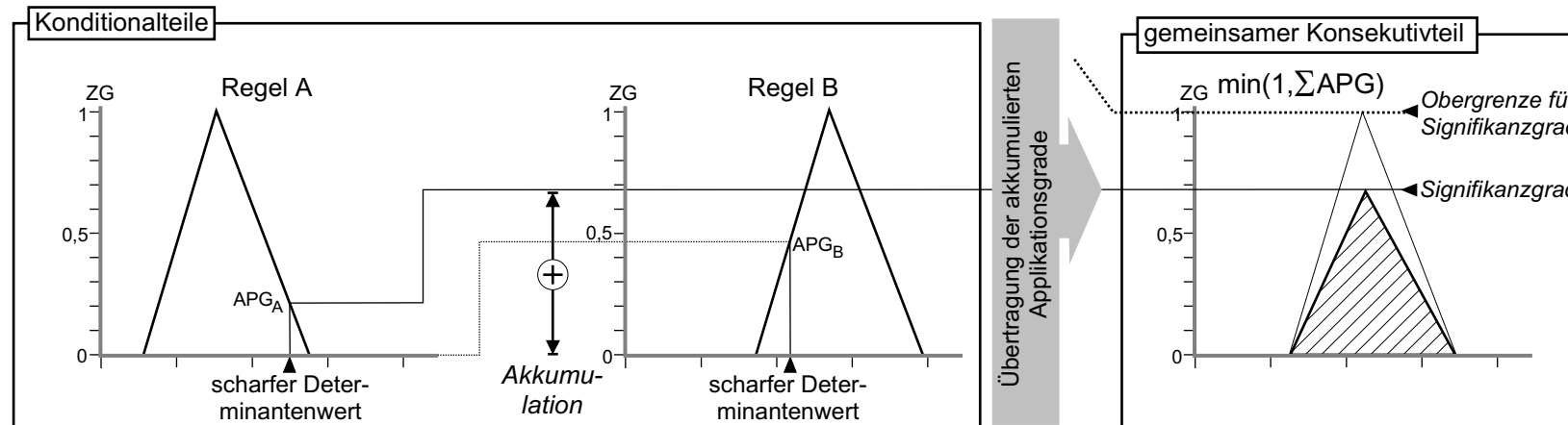

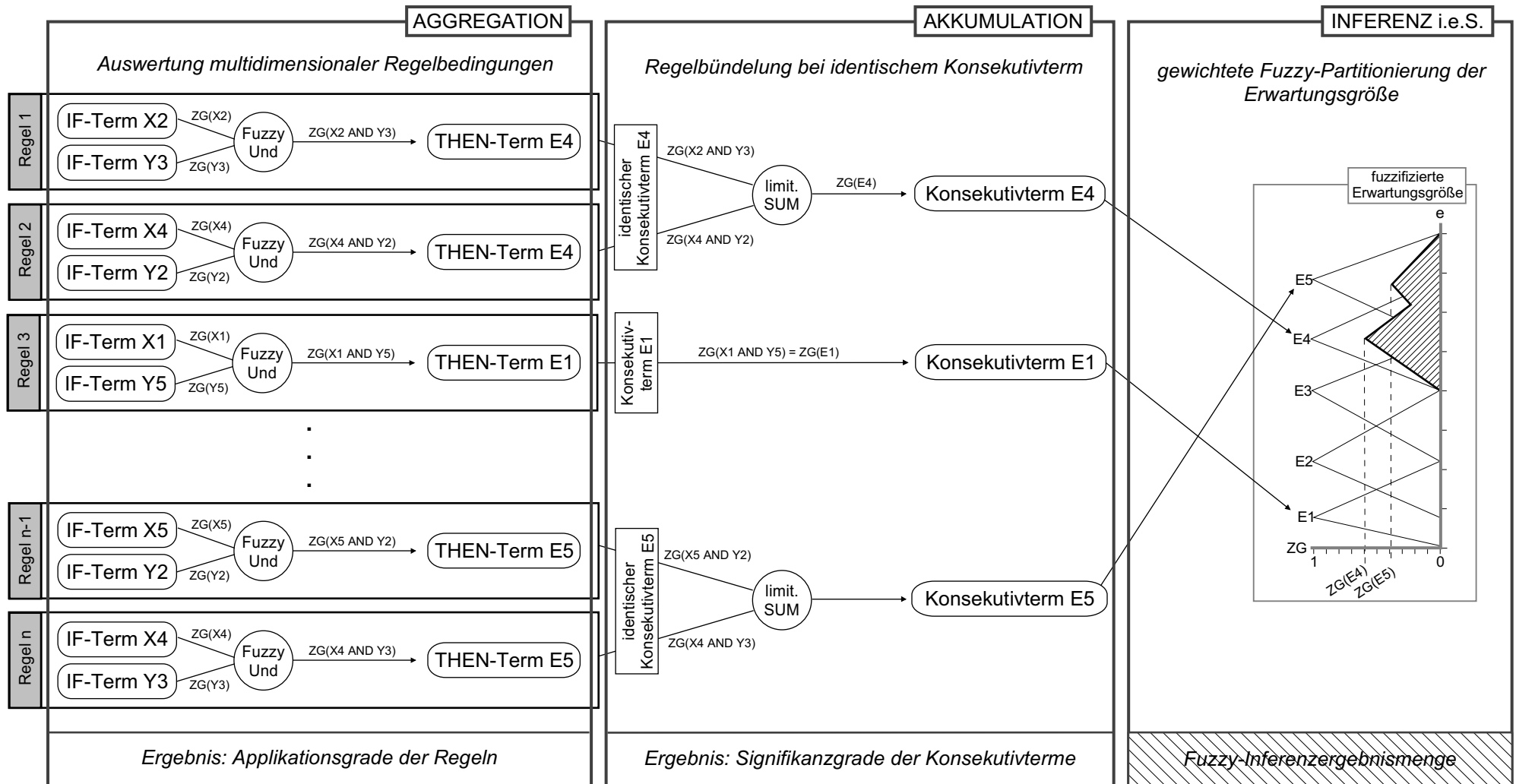

Center-of-Area-Verfahren

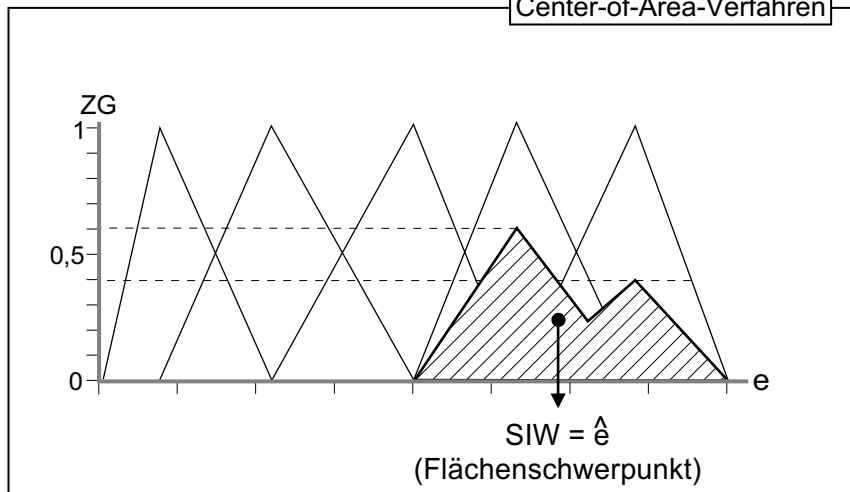

Center-of-Maximum-Verfahren

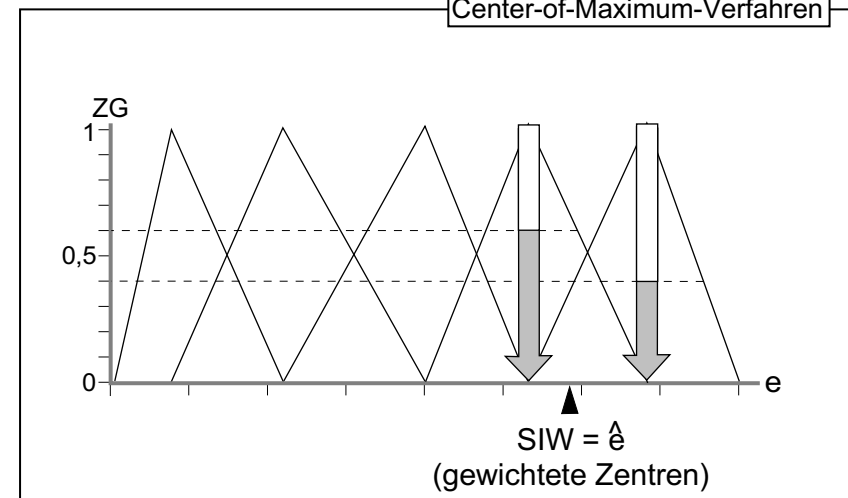

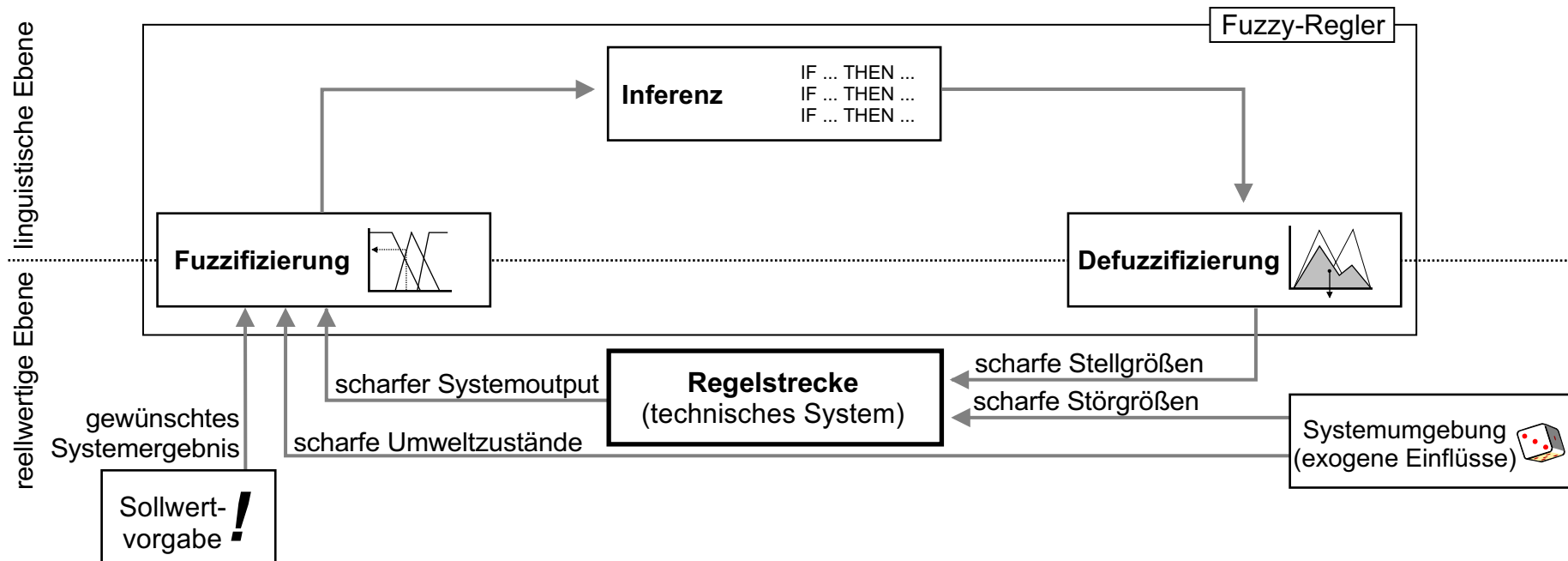

a) Fuzzy-Regelung (fuzzy control)

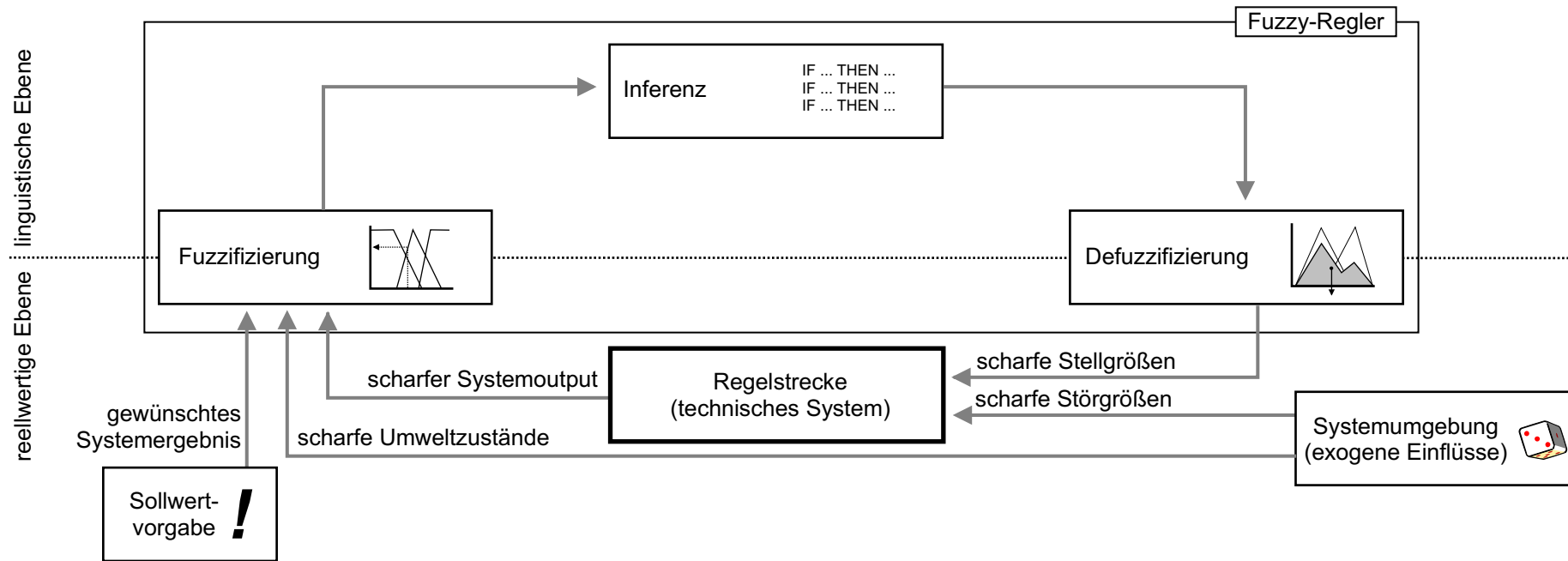

b) Fuzzy-Erwartungsbildung (fuzzy expectations)

